

ZonneWarmteNet

getest op 'Green Village' (TU Delft, faculteit Bouwkunde)

Techniek partners:



Techniek

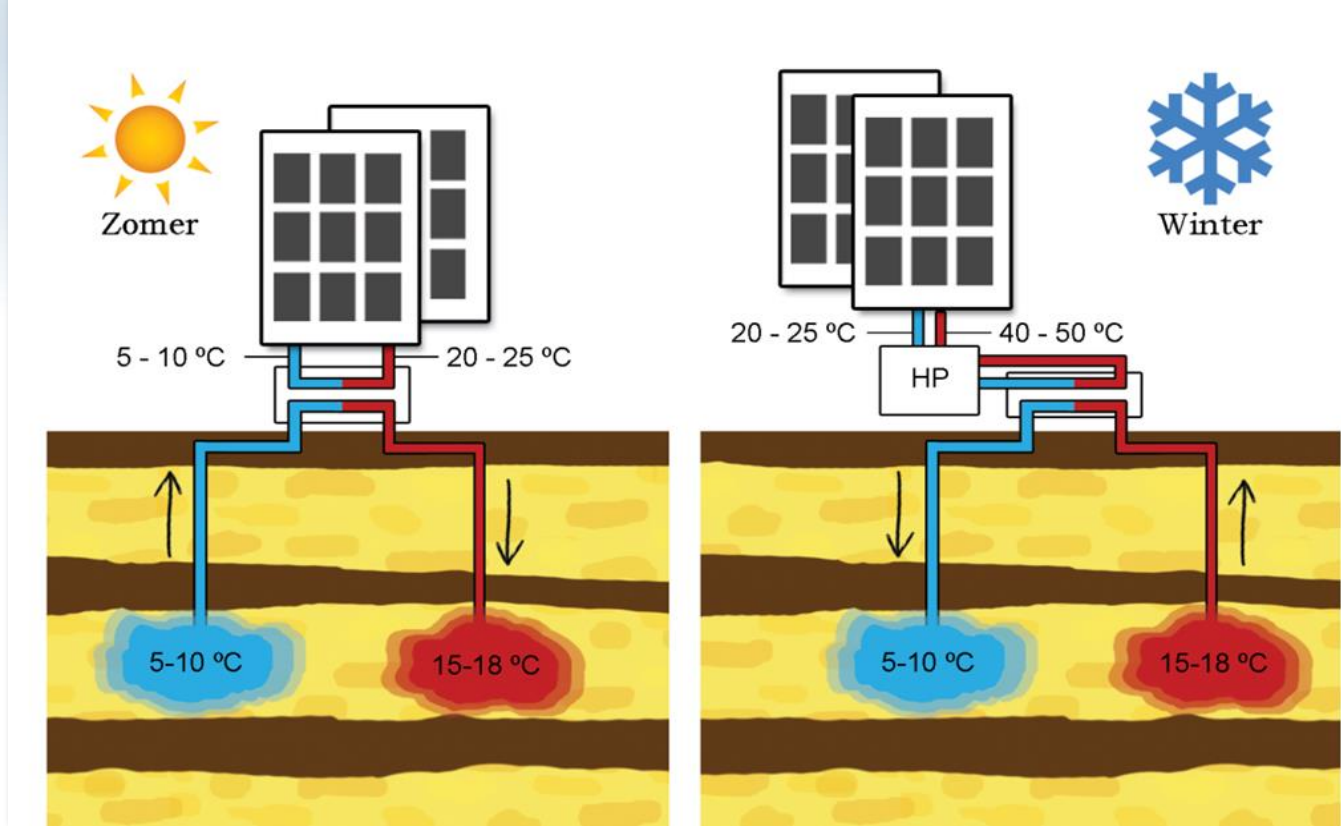
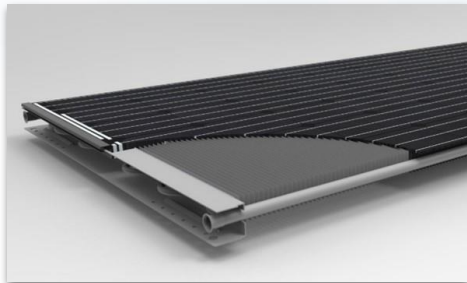

Gebruik van wijknet, per seizoen

ZonneWarmteNet - Zomer

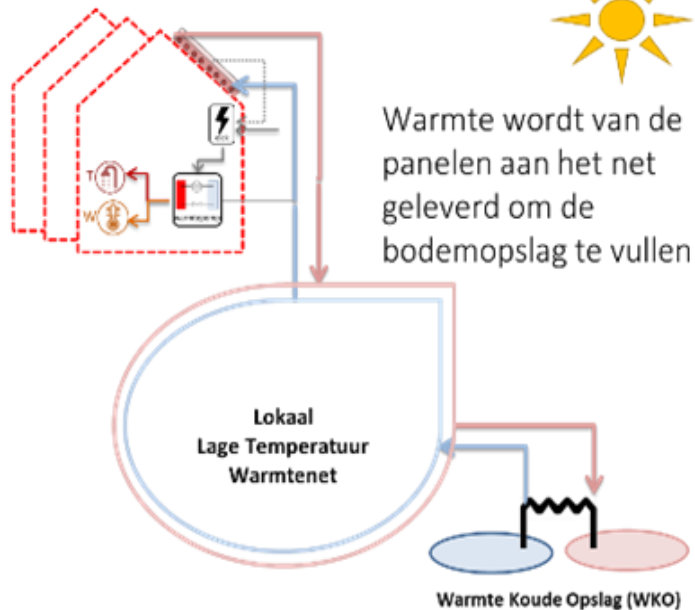

ZonneWarmteNet - Tussenseizoen

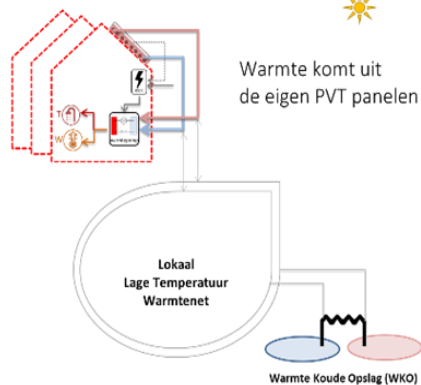

ZonneWarmteNet - Wintersituatie

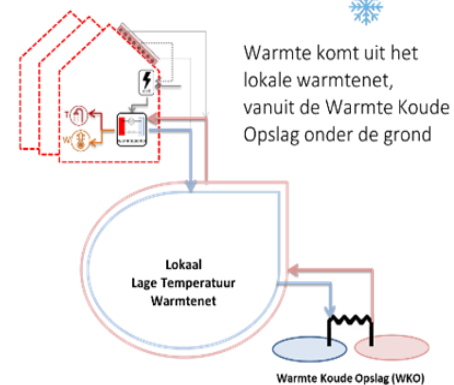

Conclusie van het onderzoek

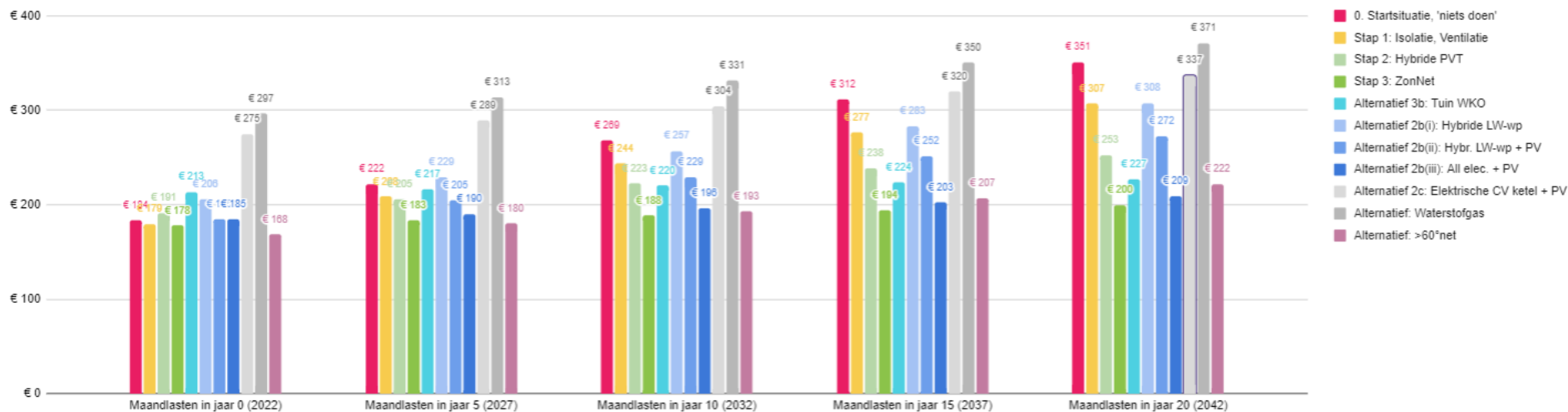

PVT-warmtepomp + ZonWarmteNet =

meest duurzaam, laagste maandlasten en hoogste rendement

Stappenplan

Aanbod+ (incl. bespaar-calculator, energie-advies en ontzorg-service)

Pakket 1. Isolatie+ (basis-isolatie, ventilatie, afgifte)

Pakket 2. Opwek+ (PVT zonnepanelen, geluidsarme water-water warmtepomp)

Pakket 3. Opslag+ (afleverset, wijknet, WKO)

ten slotte: CV ertussenuit (boilervat, inductie)

Startsituatie

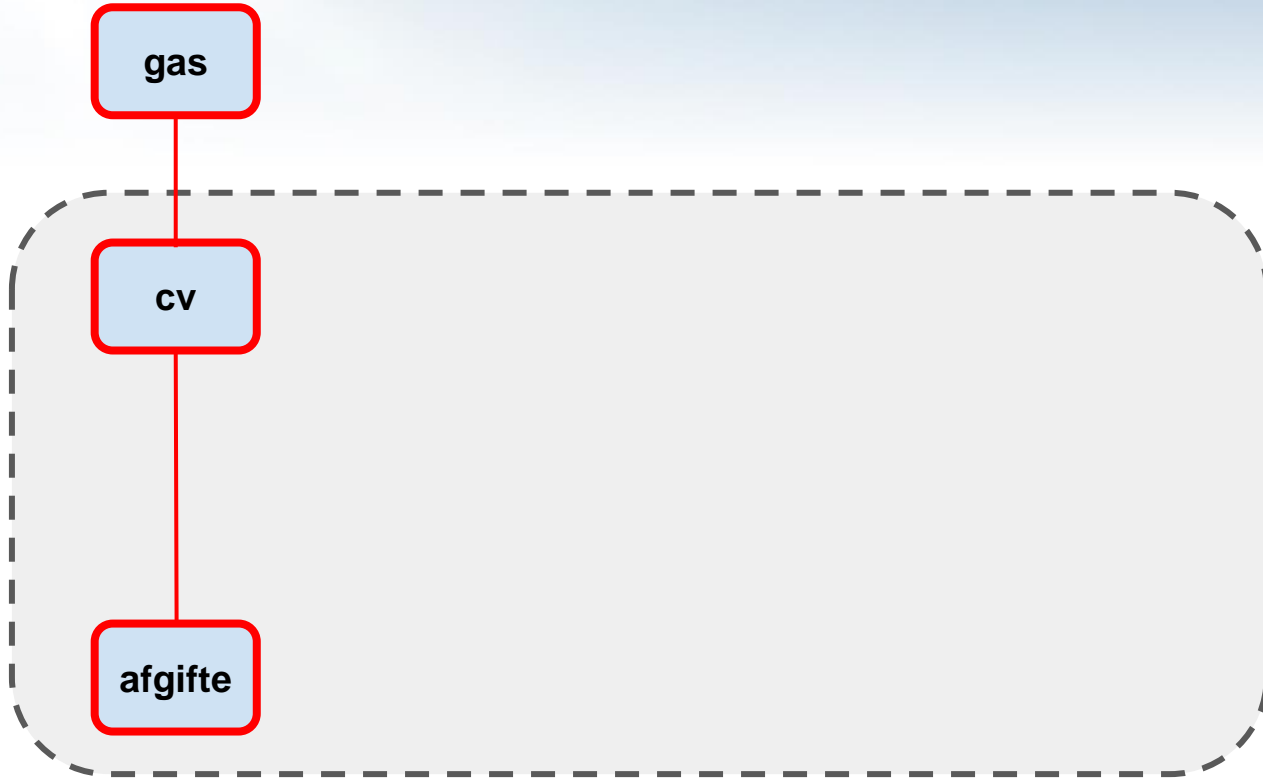

Aanbod+

gas

cv

afgifte

Concept aanbod *Na de zomer - voor iedereen*

- online huisdossier
- bespaar calculator

Definitief aanbod *Begin 2022 - voor leden*

- subsidie scan
- **professioneel energie advies:** welke isolatie, hoeveel PVT, etc.
- **ontzorgen van financiering**
- **ontzorgen van uitvoering:** collectieve inkoop, aanleg, onderhoud etc.

Pakket 1: Isolatie+ (basis-isolatie, ventilatie, grotere radiator)



A. Basis-isolatie:

- ramen
- gevel
- vloer of dak
- kierdichting

B. Ventilatie

C. Evt. grotere radiator

Pakket 2: Opwek+ (PVT zonnepanelen, warmtepomp)

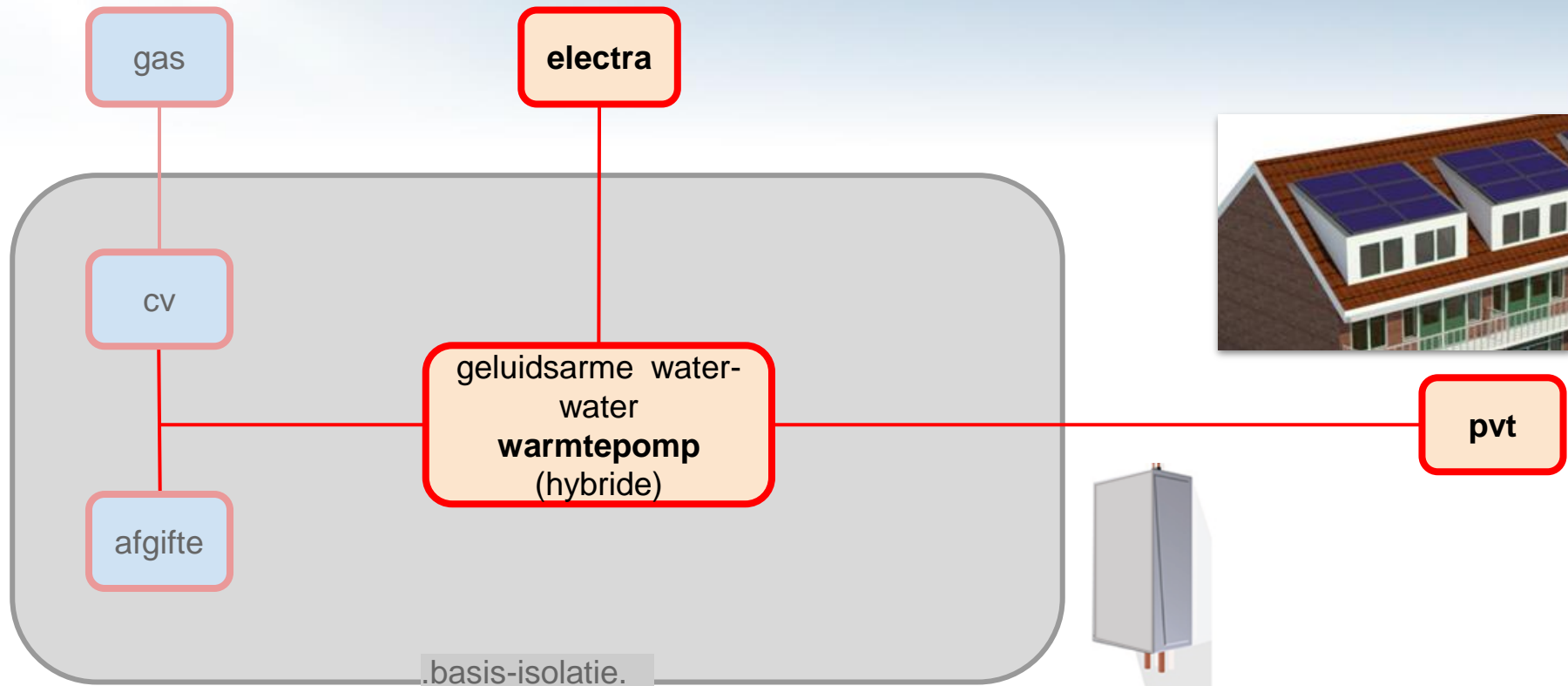

Pakket 3: Opslag+ (Afleverset, wijknet, WKO)

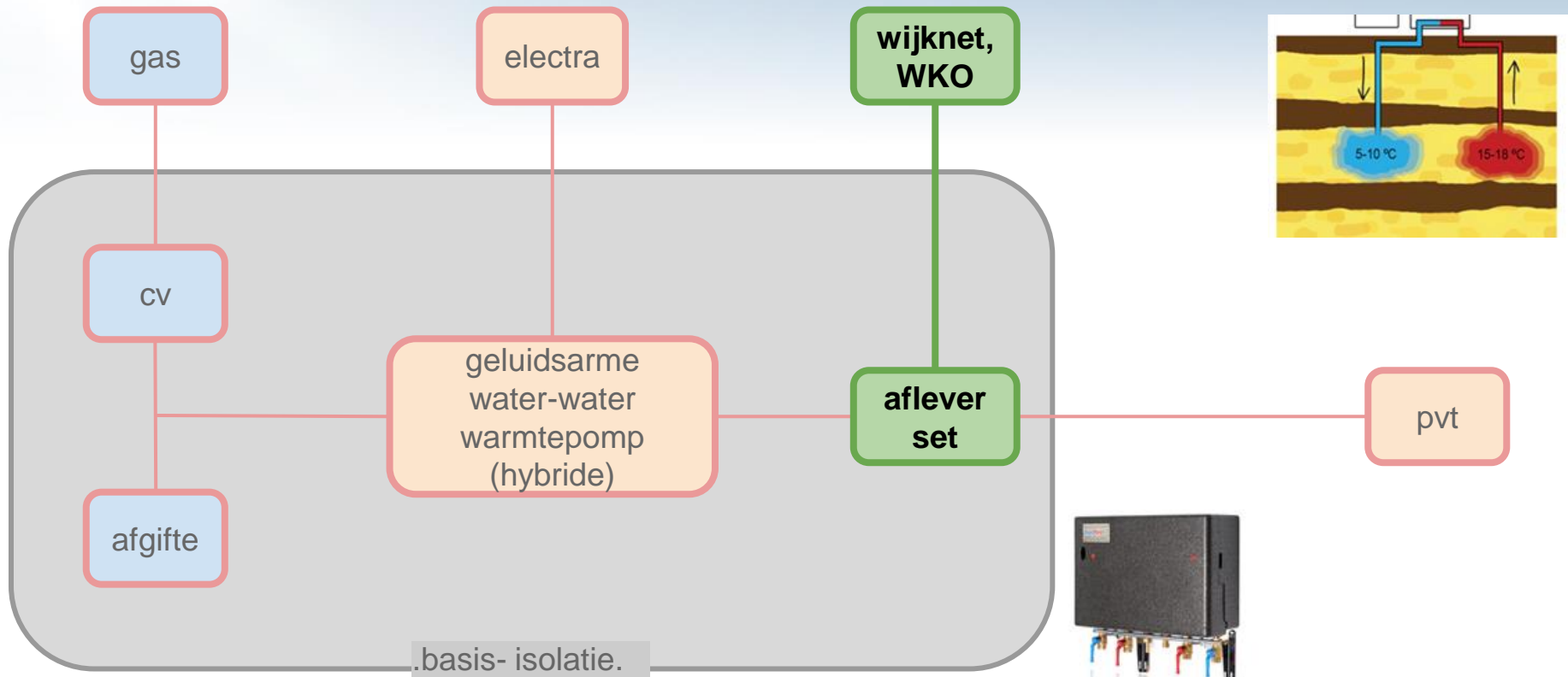

Tenslotte: CV er tussenuit (nodig: boilervat, inductiekoken)

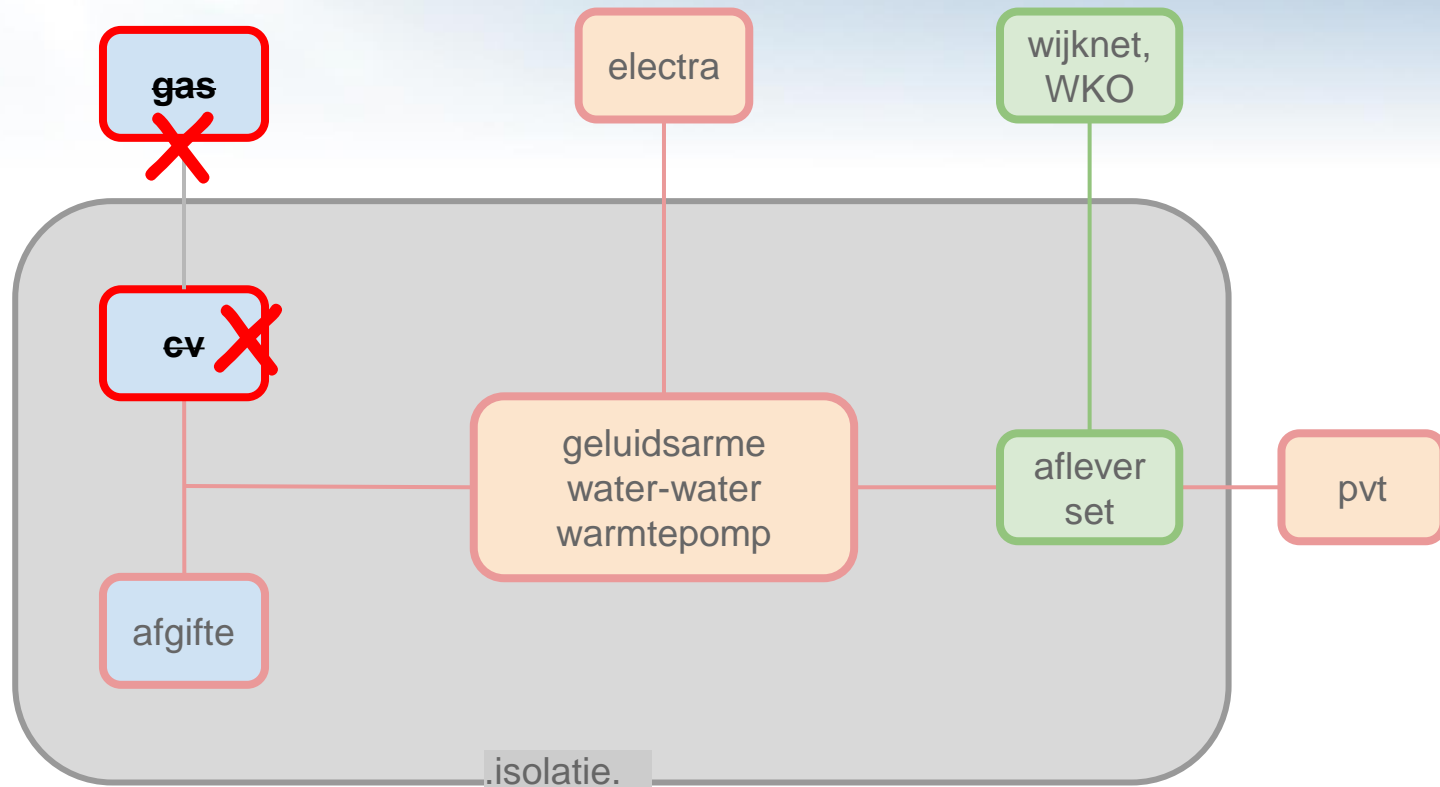

Organogram

→ eigenaar

- - - > service

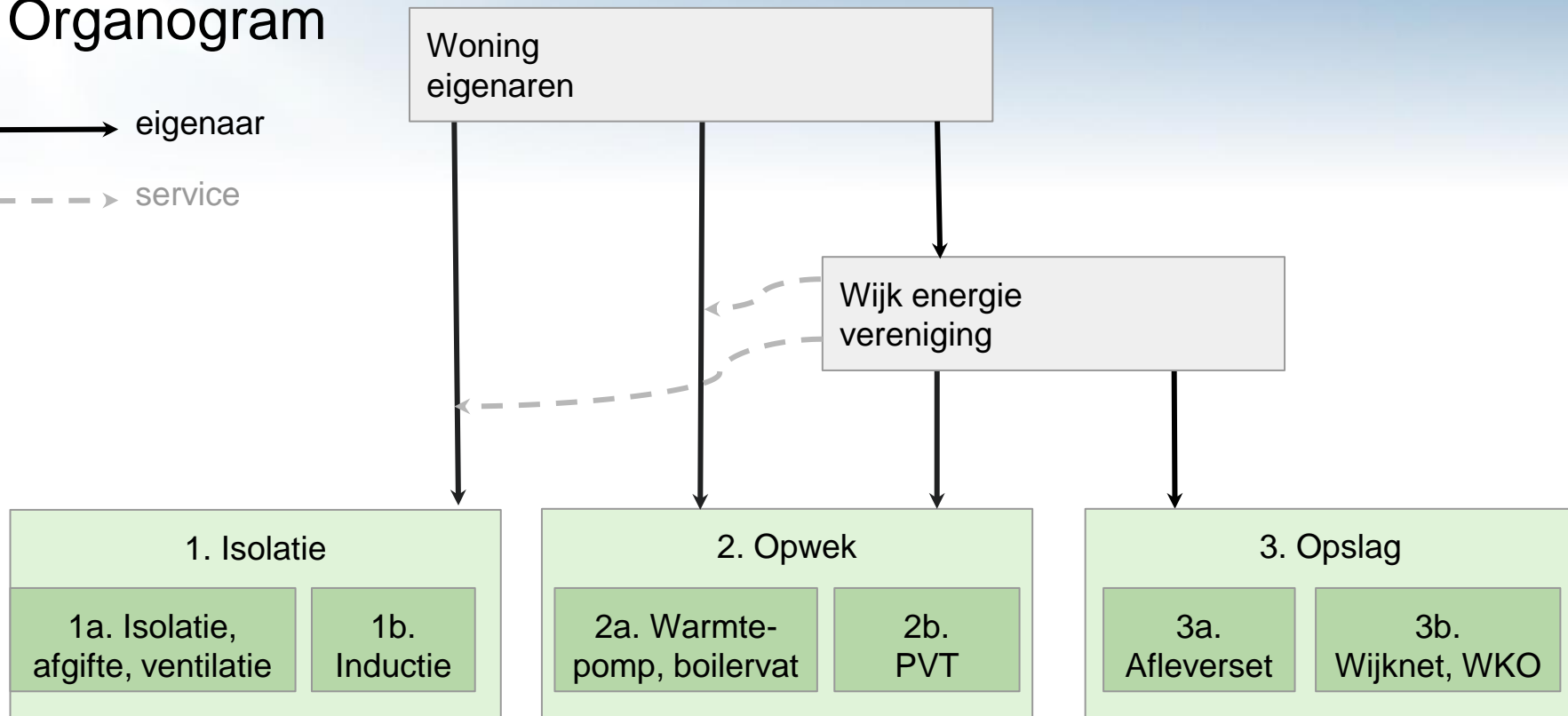

Organogram

→ eigenaar

- - - > service

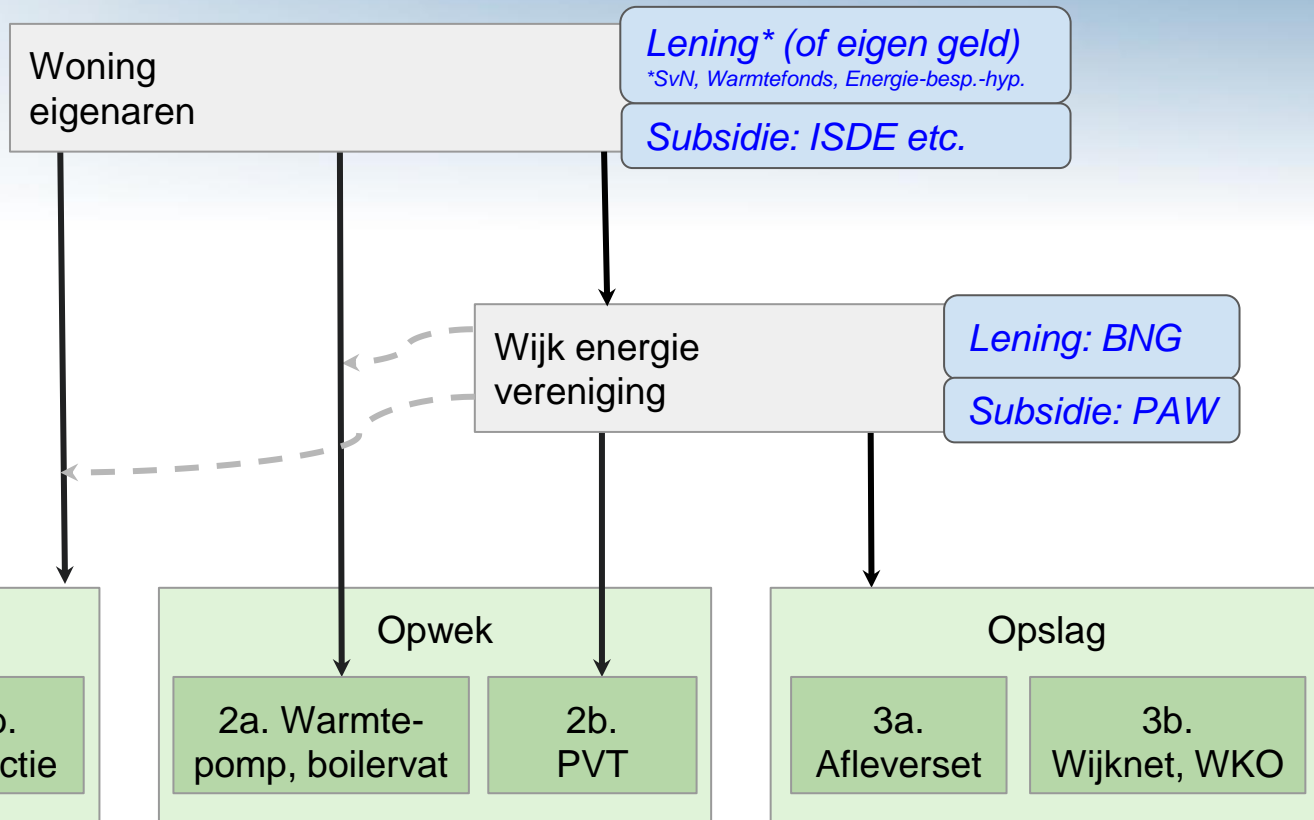

Voorbehoud

Financieel voorbehoud:

1. Lage rente (1,6% en voor het wijknet zelfs maar 1,3%)
2. Lange looptijd van de lening (20 jaar en voor het wijknet zelfs 30 jaar)
3. Subsidie zodat het 'niet meer kost dan anders'

Extra voorbehoud voor het gedeelte wijknet:

1. Voldoende deelnemers (dus woningen met PVT)
2. OF extra subsidie voor het wijknet

Extra voorbehoud voor huurders:

1. Elan accepteert ons aantrekkelijk aanbod

In drie stappen naar aardgasvrij - maandlasten

In drie stappen naar aardgasvrij - PVT hybride route

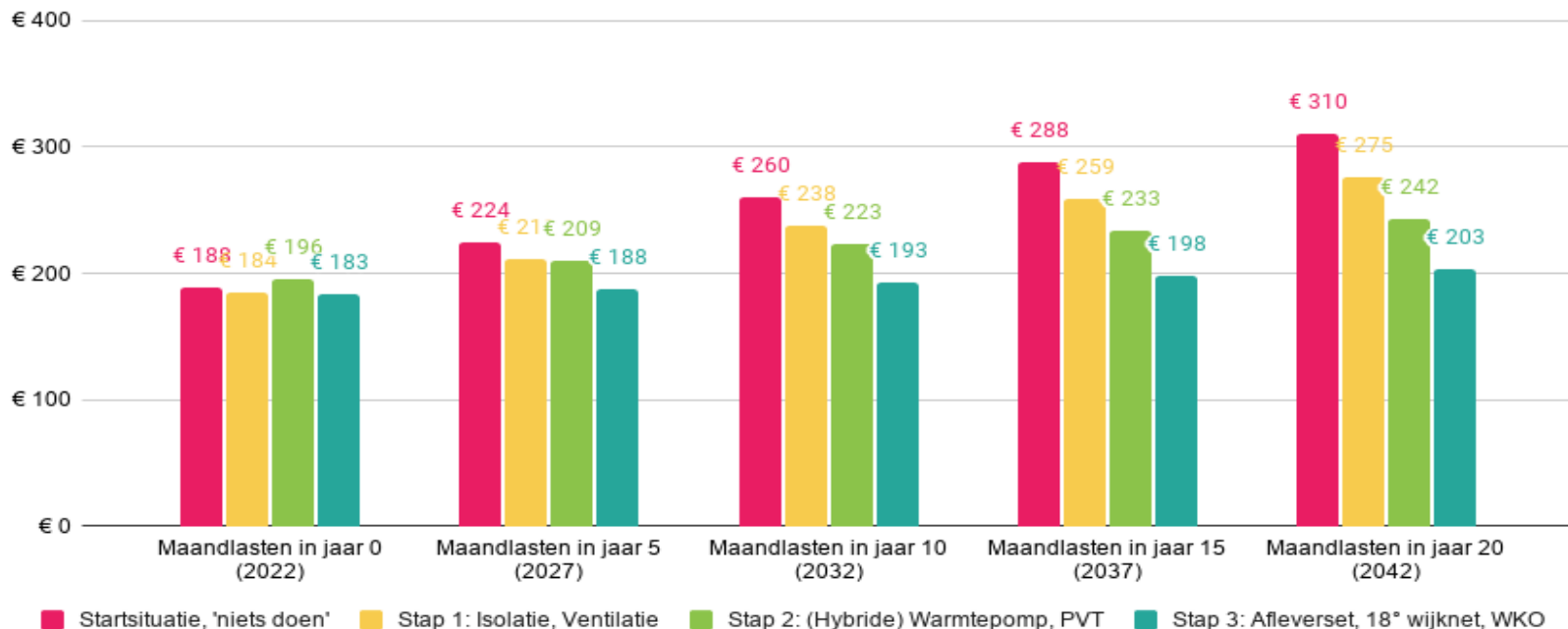

CO2 uitstoot (kilogram CO2 / woning / jaar)

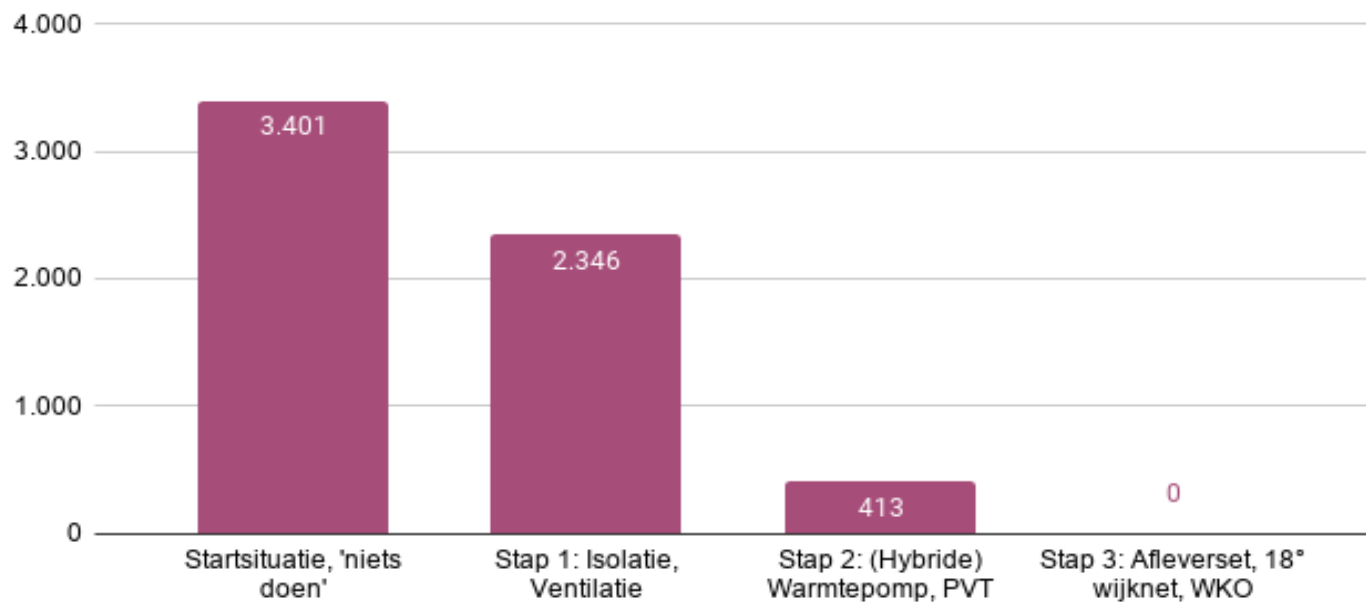

VRAGEN

An aerial photograph of a residential neighborhood. In the foreground, there are several large, reddish-brown tennis courts. A church with a steeple is visible near the courts. The neighborhood consists of many houses with red roofs, interspersed with green trees. In the background, there are more houses and a large green field. The sky is blue with some light clouds.